

Megger[®]

PAT4DV/3 & 4DVF/3

Portable Appliance Testers

User Guide

Contents

Safety	2	Testing an Asset	27
General Description	3	Auto Restart to Main screen	28
Fuses	4	Repair Codes	28
Features and Controls	5	Historical Data	29
Setting Up	6	Quick-Check	30
Contrast Adjustment	6	Erase Memory	31
Reset to default settings	6	Printing Reports and Results	32
Shortcut to Comms Upload (from PC)	6	Download/Upload Data	33
Results print-out after test	6	Download to a Computer	34
Logging in to the unit	7	Upload from a Computer	35
User names and PIN numbers	8	Description of Tests	36
Setup Manual/Autopass Testing/Fail Buzzer	9	Visual Inspection List	36
Setup Test Times	10	Earth Bond Test	37
Setting the Clock	11	Earth Continuity Test	37
Setting Up the Test Company Title	12	Circuit Test (Pre-Test)	38
Barcode Scanner	13	Insulation Test	38
Clients and Locations	14	Operation Test	38
Selecting an existing Client and Location	15	Earth Leakage (Touch Current) Test	39
Adding or editing a Client	16	Fuse Test	39
Adding or editing a Location	17	Extension Lead Testing	39
Erasing a Client or Location	18	Flash Test (PAT4 DVF only)	40
Asset Test Groups	19	Demonstration Data	41
Adding, editing or erasing a Group	21	Specification	44
Assets	22	Accessories	47
Adding an Asset	23	Repair and Warranty	48
Editing or erasing an Asset	24		
Locate an Asset	25		

SAFETY

Symbols used on the instrument.



Caution: Refer to accompanying notes



Risk of electric shock.



Equipment complies with relevant EU Directive



SAFETY WARNINGS

- Safety Warnings and Precautions must be read and understood before the instrument is used. They must be observed during use.
- For safety, **PAT4 must be properly earthed**. Only use a supply socket that has a protective earth contact. If there is any doubt as to the effectiveness of the supply socket earth, connect a known good earth to the earthing point on the **PAT4** front panel.
- Test leads, probes and crocodile clips **must** be in good order, clean and with no broken or cracked insulation. The flash test probe **must** be held behind the handguard, and only be connected to the **PAT4** for the duration of the test.
- For safety, tests are performed in the correct order. If an asset (appliance) fails a test, **PAT4** will fail the asset and exit the test sequence. The fault causing the failure must be corrected before the appliance is re-tested.
- During testing, ensure that no hazard will exist if the asset operates as a result of normal running, or of a fault condition.
- Assets should **not** be routinely flash tested.
- Where assets have to be flash tested, see '**Flash Testing – Warnings**' on page 11.
- When performing an Insulation test the asset **must not be touched**.
- Only perform an Operation test **after** an Earth Bond Test (Class 1 only) and Insulation Test (Class 1 or Class 2) have been verified.
- The instrument should **not** be used if any part of it is damaged.
- Replacement fuses **must** be of the correct type and rating. See '**Fuses**' section.

NOTE: THE INSTRUMENT MUST ONLY BE USED BY SUITABLY TRAINED AND COMPETENT PERSON

General Description

The **PAT4** Portable Appliance Testers provide significant advances in the ease of use, with features designed to speed up the testing of electrical equipment. The instruments meet the testing requirements of the UK Electricity at Work Regulations and the IEE Code of Practice for In Service Inspection and Testing of Electrical Equipment. The instruments may be used stand alone, or for maximum advantage, with PC based software, such as **XPress™** software for Windows™ (See Accessories). The integral real time clock 'stamps' an accurate time and date on every test. **PAT4** utilises a unique concept known as Test Groups. This permits very rapid addition and testing of equipment with a minimum of data entry. Once set up, the use of Test Groups will save a great deal of time. Additionally, Test Groups ensure that only the correct tests can be applied to the equipment under test and eliminate the need for complex test codes.

PAT4 provides a professional system for the rapid testing of equipment while maintaining the essential traceability of asset test history. The on-board Asset (Appliance) database keeps a record of appliance details, re-test frequency, test and re-test dates, and allows the previous test results to be displayed at the time of test. As well as the easy to use QWERTY keyboard, each field is named, so there is less chance of entering the wrong information. Data entry via optional bar code scanners is also possible. The lithium backed 'real time' clock maintains the time and date accurately for over ten years and automatically date and time stamps every asset tested. Data is stored in battery backed, solid state memory that under normal circumstances will be protected for ten years. Such storage media is however susceptible to external influences such as transients and static discharge. These effects may cause data corruption or loss. Megger Limited cannot accept responsibility for any such losses of data. When the **PAT4** is used with PC software such as **XPress™** software, employing good working practices, such as the regular downloading of data will substantially reduce the risk.

The following information can be stored and accessed directly on the **PAT4**.

• Assets (Appliances) - total number	1000	• Locations (Site details)	20
• Results (sets of)	1000	• Test Groups	50
• Clients (names and addresses)	10	• Users	10

The instruments can perform the following tests:

- Visual Inspection list
- Fuse Test
- Circuit test (pre-test)
- Earth Bond test
- Earth Continuity test
- Insulation test
- Operation test.
- Earth leakage test.
- Extension Lead test.
- Flash test (**PAT4 DVF** only).

Fuses

Due to the often harsh electrical environments in which Portable Appliance Testers are used and the likelihood of testing faulty equipment all Megger Portable Appliance Testers are protected by appropriate internal fuses. This ensures that the instrument is protected from serious damage.

An unfortunate downside to using internal protection fuses is that the PAT4 can be rendered inoperative simply by the failure of such a fuse resulting in frustration and delay for the user. In order to ensure that the instrument can quickly be put back into service without downgrading its protection externally located fuses are now fitted to all new PAT4 models. These may be changed quickly and simply by the user in the event of a failure. For maximum convenience all fuses are of the same value.

Additionally the PAT4 display will now indicate which fuse has failed, unless of course it is main supply fuse in which case the screen will be blank.

Replacement of Fuses

Always disconnect the PAT4 from the main supply before checking fuses. Use correct replacement fuses as printed adjacent to the fuse

Megger Part No. for replacement fuses 25950-014

Using your PAT4

Connecting to the Power supply

Plug the **PAT4** into a standard 230 V supply for testing 230V appliances or into a 110V supply for testing 110V appliances. A 110V 'site' or 'tool' transformer may be used.

On connecting to the supply, the **PAT4** performs a rapid self-test and calibration sequence. If the screen is dim, refer to Contrast adjust.

* For 230 V 60Hz operation see note on Earth Leakage, page 45

Features and Controls

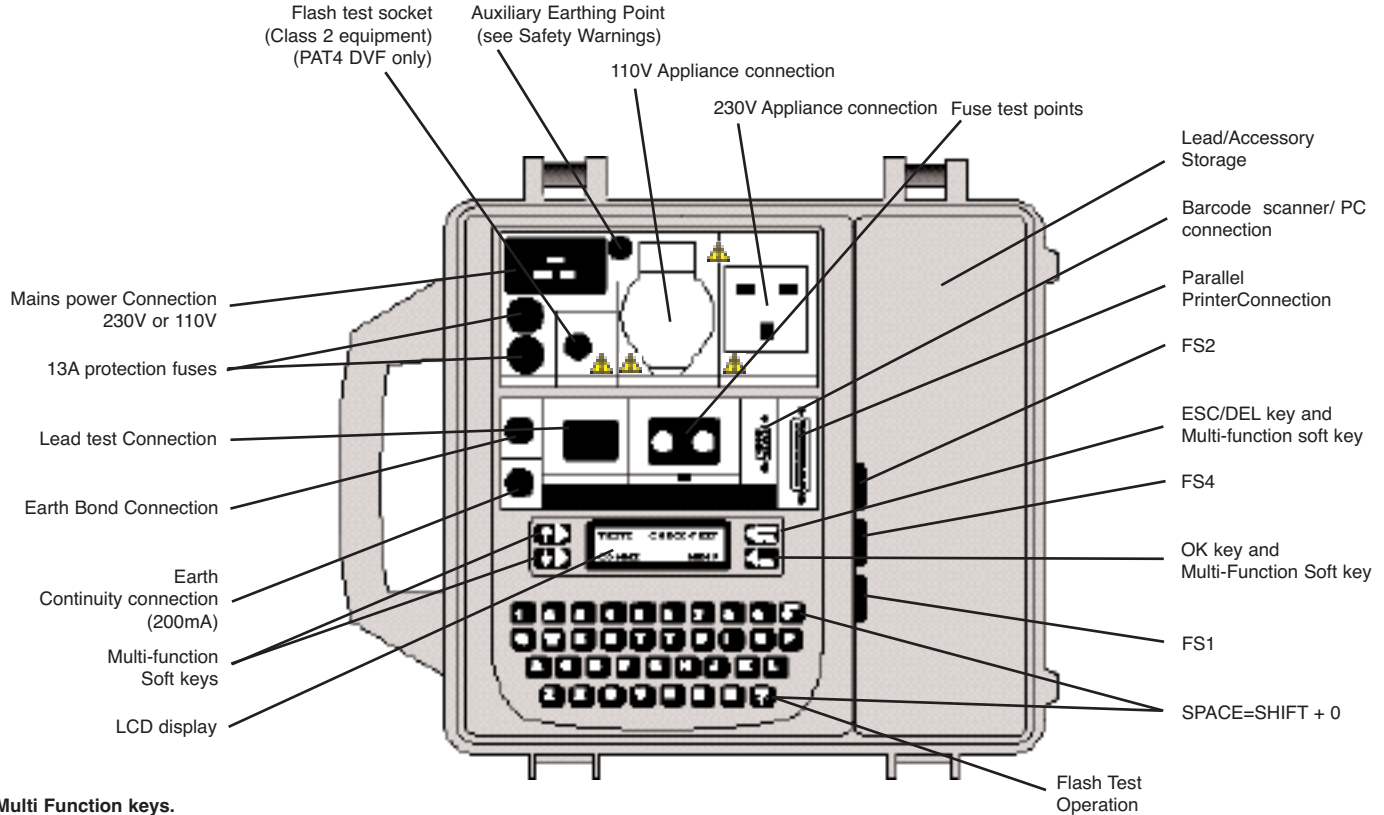

Multi Function keys.



ESC DEL ESCape back to previous screen or used to DElete typed text.

OK OK when there is no displayed function.

Setting Up

Contrast Adjustment

PAT4 has been designed so that contrast adjustment will not normally be required unless working at extremes of temperature.



- 1 Press and hold the letter '**C**' key during the full switch on sequence. The Contrast screen is displayed.
- 2 Press the left hand keys repeatedly, to adjust the contrast as required and press the **OK** key.

Reset to default Settings

If desired, the **PAT4** can be reset to the factory default settings, and re-instate the demonstration data.

Note: **All existing data and User configurations will be erased.**

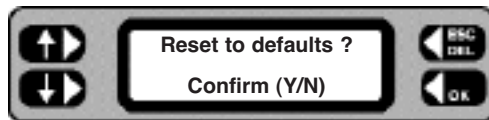

- 1 Press and hold the letter '**R**' key during the full switch on sequence. The adjacent screen is displayed:
- 2 Confirm the request using the '**Y**' key. On completion, you will be returned to the Login screen.
- 3 Use 'AVO' and '1 2 3 4' as the User / Pin to re-start.

Shortcut to Comms Upload (from PC)

If there is no useful data stored in **PAT4**, and it is required to upload new data from a PC, this short cut allows direct access to the "COMMS RECEIVE" mode.



- 1 Press and hold the letter '**U**' keyboard key during the full switch on sequence. The 'Erase Data' screen is displayed.
- 2 Press **EXIT** to cancel the erasure, or **CONTINUE** to proceed. The 'Are you sure ?' screen is displayed.
- 3 Press the **YES** key to confirm, or cancel by pressing the **NO** key.

Results print-out after test

PAT4 can be selected to print a short report of the test results immediately after each test. To toggle the status of this feature from off to on or vice versa, press and hold the 'P' key during the full switch on sequence. Note: No screen is displayed to show that the change has occurred.

Logging in to the Unit

PAT4 accepts up to ten User names / PIN numbers at any one time, allowing only authorised persons to use the unit, if required. To input User names and their respective pin numbers see '**Settings**'. Tests are attributed to the user that is currently logged in.



If you have not used the **PAT4** before:

- 1 Type in the name AVO. Typing errors can be deleted using the **ESC/DEL** key. Press the **OK** key.
- 2 Type in the PIN number 1234 and press the **OK** key. The current Client will be briefly displayed followed by the Client screen.

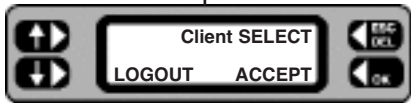

- 3 Press the **SELECT** key. The Client Selection screen is displayed.



- 4 Press the **NEXT** key repeatedly. Each time the key is pressed, the next Client is displayed.
- 5 When the screen displays the desired client, press the **OK** key. This selects the displayed client as the current client. The 'Location' screen is now displayed.

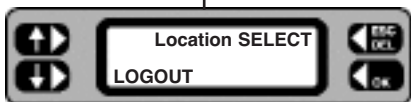

- 6 Press the **SELECT** key in order to view and choose the site or building location.



- 7 Press the **NEXT** key repeatedly. Each time the key is pressed the next location within the selected client is displayed.

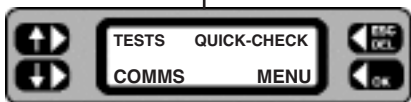

Main Screen

- 8 When the screen displays the desired location, press the **OK** key. This selects the displayed location as the site location you are currently using. The Main screen is displayed.

The Client and Location need be selected only once for any particular site. **PAT4** will assume the same settings until you deliberately logout from the Client. Even if mains power is removed e.g. when moving around a site, if you have not logged out, the **PAT4** will automatically return to the Main screen.

User names and Pin numbers

Names and Pin numbers for up to 10 authorised Users can be entered at any time. Test results are individually credited to the person logged in at the time of testing and downloaded to Megger software if used.

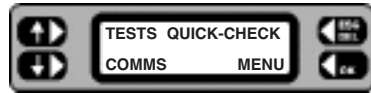

1 From the Main screen, press the **MENU** key.



2 From the Menu screen, press the **SETTINGS** key.

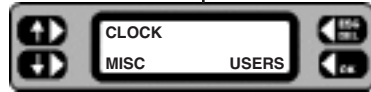

3 Press the **USERS** key.

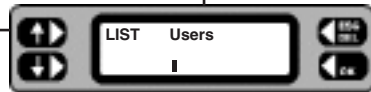

4 To check current Users, press the **LIST** key.

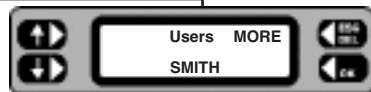

5 Use the left hand keys to scroll through the user list. The user who is currently logged in is displayed with an asterisk * against the name. To edit or erase a user scroll until the required user is displayed.

6 Press the **MORE** key. The softkey options are displayed. From this screen you can **ADD** a new user, **EDIT** or **ERASE** the currently displayed user.

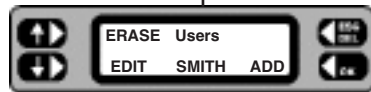

7 To add a new user, press the **ADD** key.

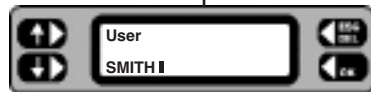

8 Type in the new User name then press the **OK** key.



9 Type in the desired PIN number (4 digits), press the **OK** key to save the user and PIN.

To login a different User, the current User must first be logged out - refer to the Client/Location Selection flow chart - press the **LOGOUT** key. The User/PIN screen is displayed.

Setup Manual / Autopass Testing / Fail buzzer

If 'AUTOPASS' is selected, testing will proceed automatically with **PAT4** determining the pass/fail status according to the pre-selected Group limits. If 'MANUAL' is selected, **PAT4** will pause after each test and display a "Pass" / "Fail" decision prompt. The buzzer can be set to sound when a test fails in **AUTOPASS** mode. To mute the buzzer following a failure, press the **OK** key.

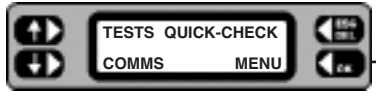

1 From the Main screen, press the **MENU** key.

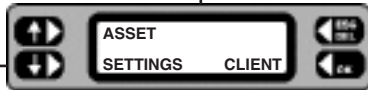

2 From the Menu screen, press the **SETTINGS** key.



3 Press the **MISC** key.



4 Press the **TEST SETUP** key. The current Manual / Autopass setting is shown.

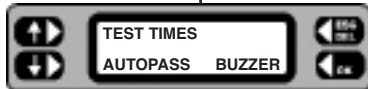

5 Using the lower left key, toggle the Manual / Autopass setting as required.

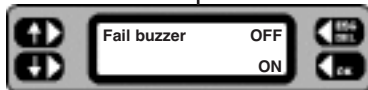

6 To set up the Fail buzzer, press the **BUZZER** key. Using either the **OFF** or **ON** key, switch the buzzer feature off or on as required.

7 On completion use **ESCAPE** to back up to the Menu screen (and Main screen if required).

Setup Test Times

Each test can be performed for a User definable time of between 5 and 60 seconds (5 and 20 seconds for Bond test). This enables specific tests to be set to appropriate lengths of time, perhaps to satisfy a particular standard. Once set, a test time will automatically be applied to all assets using such a test, regardless of the Group, Client or Location.

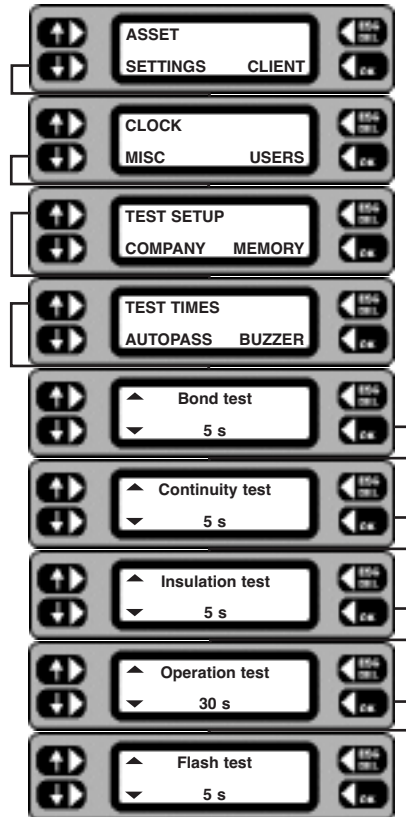

1 From the Main Screen, press the **MENU** key.

2 Press the **SETTINGS** key.

3 Press the **MISC** key.

4 Press the **TEST SETUP** key.

5 Press the **TEST TIMES** key. The first test is displayed with its current time setting.

6 Operate the left hand keys to adjust the time for the selected test, then press the **OK** key to store the test time as displayed. The next test and its current duration is displayed.

Note: Press the **ESCAPE** key at any time to exit test time setup.

7 When the final test time has been setup and **OK** pressed, the display returns to the Test Setup screen.

Setting the Clock

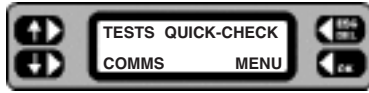

1 Press the **MENU** key.

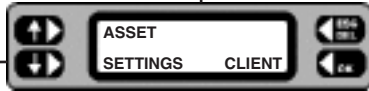

2 Press the **SETTINGS** key.

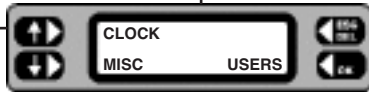

3 Press the **CLOCK** key.

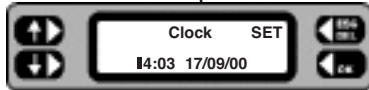

4 Press the **SET** key. The Clock adjustment screen is displayed, with the cursor flashing on a character.

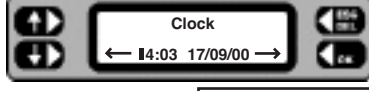

5 Using the lower keys, move the cursor as appropriate and type in the required settings.

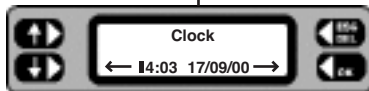

6 On completion of the setting, repeatedly press the **OK** key to move the cursor to the extreme right until it disappears.

7 Press the **OK** key again to return to the Settings screen.

8 Use the **ESCAPE** key to return back to the Menu screen.

Setting up Test Company Title

PAT4 offers the ability to enter your Test Company title. This setup should not be confused with Clients and Locations. The Test Company is the name of the organisation operating the **PAT4**. eg. 'XYZ Testing Ltd.' Once entered, the company title will be printed as the header on the reports available from **PAT4**.

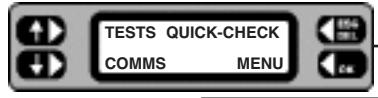

1 Press the **MENU** key.



2 Press the **SETTINGS** key.

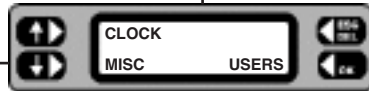

3 Press the **MISC** key.



4 Press the **COMPANY** key.



5 Type in the title of the testing company (20 characters).

Use the **DEL** key to correct any typing errors.

6 On completion press the **OK** key to return back to the Miscellaneous screen.

7 Press the **ESC**ape key to return back to the Menu screen.

Barcode Scanner

The optional **PAT4** barcode scanner (6231-623) can be used to speed up the collection of asset data.

On subsequent visits it can also allow rapid retrieval of stored asset details when used in conjunction with barcoded asset labels. **PowerSuite™** can be used to produce custom barcode labels, or alternatively pre-printed barcode asset labels are available from **Megger Limited** (see Optional Accessories) and other sources.

The scanner is pre-programmed at the factory to interface with the **PAT4**, and it will read the following bar code formats: Standard Code 39, Code 128, Codabar, UPC-A/E, EAN-13, EAN-8.

The **PAT4** needs no setting up to use the barcode scanner, simply plug it into the 9-way D-type connector on the front panel of the **PAT4**. The scanner will bleep a few times when it powers up.

The **PAT4** is set up to read barcodes when testing, editing or adding assets for the following fields:

Asset ID, Serial number, Asset Description and Group ID. When a barcode is scanned in these fields, the existing data is overwritten by the data that has been scanned in, and the OK key is deemed to have been pressed.

To scan a bar code, hold the scanner so that the 'mouth' of the scanner is parallel with the barcode and close enough so that the light from the scanner is illuminating the barcode. The scanner should read the barcode automatically (the trigger button on the scanner is disabled). The scanner gives a short bleep when it reads a barcode.

If a barcode is scanned which is longer than the data field in the **PAT4**, the data received will be truncated.

In order to be able to scan Asset Descriptions and Group ID's, you will need to prepare a sheet containing the text barcodes you wish to enter. **PowerSuite™** can print these barcodes.

Clients and Locations

PAT4 maintains separate sets of assets (appliances) testing records by Client. Each Client may be allocated several Locations where different sets of assets may be found. Up to 10 Clients and a total of 20 locations may be stored at any time.

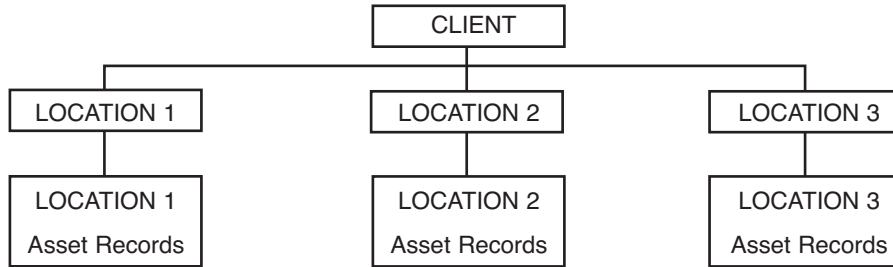

This structure enables **PAT4** to separate the testing for each location, but maintains the overall traceability to the correct Client. It also permits the same numbering sequences or asset IDs to be used for different Clients.

Where there is only one location, at least the Location name must be given; other address details can be omitted. Adding, editing or deleting of Clients and Locations can be performed either directly after Login, or from the Main screen.

Selecting an existing Client and Location

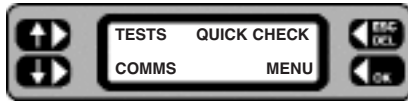

1 From the Main screen, press the **MENU** key.



2 Press the **CLIENT** key. The current client name is briefly displayed.

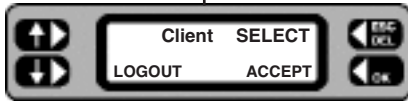

3 Press the **SELECT** key. If the **ACCEPT** key is pressed, the current client is retained and the display briefly shows the current location before moving onto step 6 below.

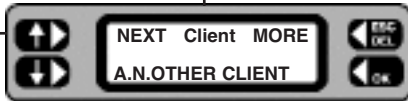

4 Press the **NEXT** key to scroll through the name list until the required client's name is displayed.

5 Press the **OK** key. The Location screen is displayed.

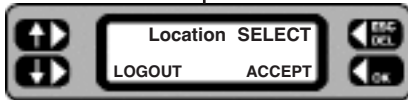

6 Press the **SELECT** key. If the **ACCEPT** key is pressed, the current location is retained and the display changes back to the Main screen.



7 Press the **NEXT** key to scroll through the list and display the required location.

Note: - If no location exists for the selected client, the program will divert to the Add location screen.

8 Press the **OK** key. The Main screen is displayed.

Adding or editing a Client

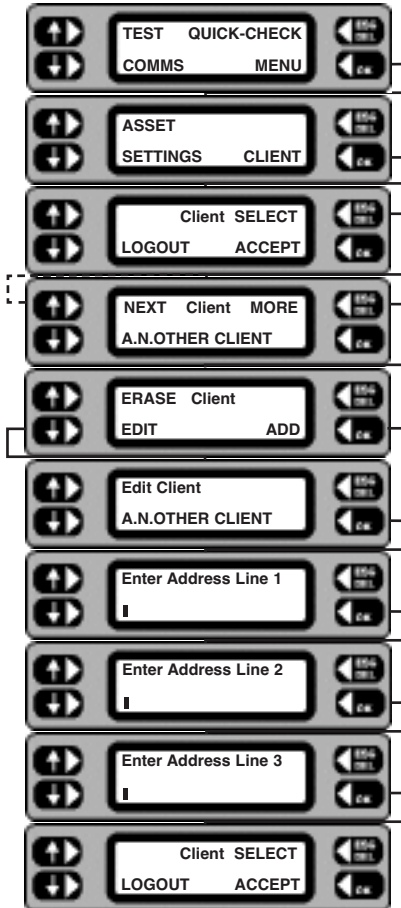

1 From the Main screen, press the **MENU** key.

2 From the Menu screen, press the **CLIENT** key.
The current client name is briefly displayed.

3 Press the **SELECT** key.

4 If editing is required, display the required client by repeatedly pressing the **NEXT** key, then press the **MORE** key. To add a client, just press the **MORE** key.

5 Press the **ADD** or **EDIT** key as required.

6 Type in or edit the client name, press the **OK** key when the Client name is complete.

7 Type in or edit the client address details, press the **OK** key to step onto the next address line.

8 When the final address line is complete, press the **OK** key, the display will briefly show the current client name.

9 Press **ACCEPT** to go on to choose a location, **SELECT** to choose another client or **LOGOUT** to select another user.

Adding or editing a Location

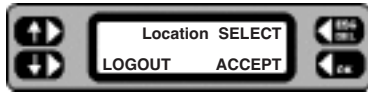

1 Select a client (see preceding instructions on how to do this) Press the **SELECT** key.

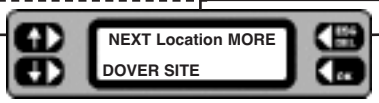

2 If editing is required, display the required location by repeatedly pressing the **NEXT** key, then press the **MORE** key. To add a location, just press the **MORE** key.

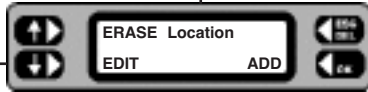

3 Press the **ADD** or **EDIT** key as required.

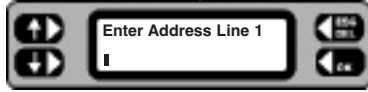

4 Type in or edit the location name, press the **OK** key when the location name is complete.

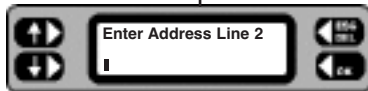

5 Type in or edit the location address details, press the **OK** key to step onto the next address line.

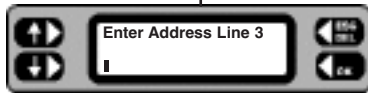

6 When the final address line is complete, press the **OK** key, the display will briefly show the current location name.

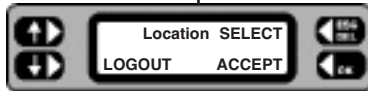

7 Press **ACCEPT** to return to the Main screen, **SELECT** to choose another location or **LOGOUT** to select another user.

Erasing a Client or Location

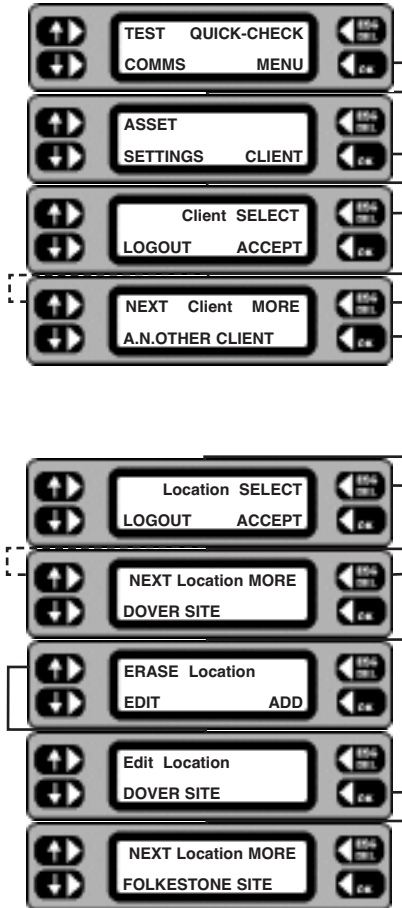

1 From the Main screen, press the MENU key.

2 From the Menu screen, press the CLIENT key. The current Client name is briefly displayed.

3 Press the SELECT key.

4 To erase a client, press the MORE key. To erase a location, press the OK key to choose the location.

5 To erase a client, follow the right hand column. To erase a location, follow the left hand column.

6 After erasing a client, a new current client must be selected.

After erasing a location, a new current location must be selected.

Asset Test Groups

Appliances are referred to as “Assets”. For each asset a complete record is stored under the appropriate Client. Each asset record holds full details of the equipment, i.e. ID; Description; Serial number; Fuse rating; Test Group, VA Rating, Test frequency, Room, and Test results.

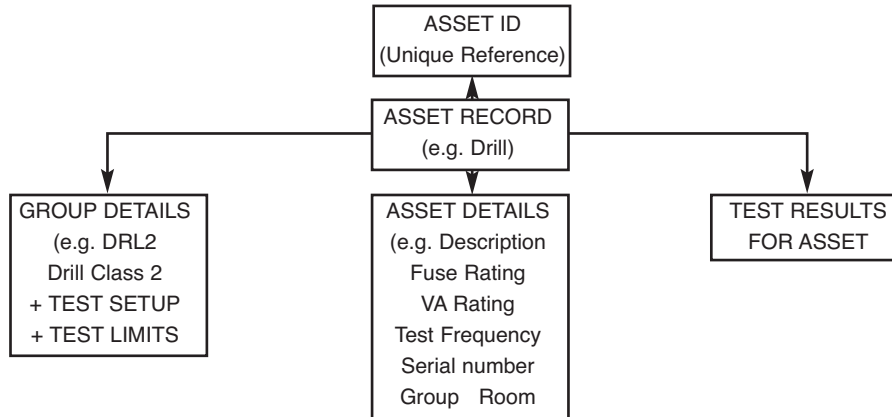

A Test Group is a set of pre-defined tests with associated pass / fail limits that are suitable for a specified type of asset (appliance). Up to 50 Test Groups may be configured, each of which is identified by a User designated 3-character code. Every asset record contains a Group **PAT4** should use when the appliance is tested.

Each Group contains the following information: -

Group Code: e.g. DRL
Group name: e.g. Drills
Voltage: 230V or 110V
Insulation Class: Class 1 = Earthed
Class 2 = Double insulated.
Tests to be applied: e.g. Bond test
Insulation test
Operation test etc.

When setting up a Group, any of the **PAT4** tests may be specified by placing a ✓ next to the selected tests.

Note: The Earth leakage/touch current test is part of the Operation test – enable the Operation test to include an Earth leakage/touch current test.

Asset Test Groups

For each selected test, PAT4 allows one of twelve pass band options to be selected.

Earth Bond: Pass < 50mΩ, 100mΩ, 200mΩ, 300mΩ, 400mΩ, 500mΩ, 600mΩ, 750mΩ, 800mΩ, 1.0Ω, 1.5Ω, 2.0Ω

Continuity: Pass < 50mΩ, 100mΩ, 200mΩ, 500mΩ, 750mΩ, 1.0Ω, 1.5Ω, 2.0Ω, 2.5Ω, 5.0Ω, 7.5Ω, 10Ω

Insulation: Pass > 0.25MΩ, 0.3MΩ, 0.5MΩ, 1MΩ, 2MΩ, 4MΩ, 5MΩ, 7MΩ, 8MΩ, 10MΩ, 20MΩ, 50MΩ

Operation: Pass < 50VA, 100VA, 200VA, 350VA, 500VA, 700VA, 1000VA, 1200VA, 1500VA, 2000VA, 2500VA, 3000VA

Earth Leakage: Pass < 0.25mA, 0.5mA, 0.75mA, 1mA, 1.5mA, 2mA, 3.5mA, 5mA, 7mA, 7.5mA, 10mA, 15mA.

Extension lead:

Checks for correct polarity, open circuit and short circuit faults. Earth Bond Test. Insulation test.

(PAT4DVF)

Flash: Pass 0.2mA, 0.3mA, 0.4mA, 0.5mA, 0.6mA, 0.75mA, 1mA, 1.2mA, 1.5mA, 2mA, 2.5mA, 3mA

Note 1: Once a Group is defined, every appliance using that group will have the same tests and limits applied

Note 2: For convenience, all Groups test for 110V assets which do not include an Operation test can be carried out using a 230V mains connection, and all Group tests for 230V assets which do not include an Operation test may be carried out using a 110V mains connection. An attempt to test an asset with an alternative voltage, when the test Group includes an Operation test, will be inhibited, and the message “Test needs xxxV please change supply” will be displayed.

Example:- Test Group for kettles as follows:

Group Code:	KET
Group Description:	Kettles
Voltage:	230V
Insulation Class:	Class 1
Earth Bond Test	Pass < 100Ω,
Insulation:	Pass > 2Ω
Operation:	Pass < 2500 VA
Earth Leakage/Touch current:	Pass < 2 mA
Flash	(not applicable)

Adding, editing or erasing a Group

-
- 1 From the Main screen, press **MENU**.
 - 2 From the Menu screen, press **ASSET**.
 - 3 From the Assets menu, press **GROUPS**.
 - 4 To add, enter the new group code and press **OK**.
To edit or erase, either enter the group code and press **OK**, or press **LIST** and scroll through the groups. When the required group is displayed, press the **MORE** key, followed by **EDIT** or **ERASE** as required.
If erasing, press **OK** on the confirmation screen to proceed with the erase.
 - 5 Type in/edit the description of the group (10 characters max.) and press the **OK** key.
 - 6 Select 230 Volt or 110 Volt assets by using the up/down Keys. Complete the selection using the **OK** key.
 - 7 Press the up/down keys to change to the required Insulation Class. Continue by pressing the **OK** key.
 - 8 Operate the up/down keys to scroll through the available tests for the group. The **OK** key toggles the test on and off, a ✓ indicating that the test is enabled. Note:- Earth Bond/Continuity tests are available for Class 1 items only.
When all required tests have been included, press the **EXIT** key.
If a Bond test has been selected an additional screen allows selection of the test current.
 - 9 For each test limit, toggle the up/down keys until the required setting is displayed, then press the **OK** key to save the setting.
 - 10 To save the new group to the memory, press the **YES** key. To cancel press the **NO** key.

Assets

Up to 1000 assets may be stored at any one time in the **PAT4**, each with their current and previous (Historic) test results. Appropriate asset details may be entered before or during testing. Once the asset record has been set and stored, it never needs to be re-entered. The next time the asset is tested, only the asset ID number needs to be entered or scanned, and the **PAT4** will recall the complete record with the correct Group code and all the asset details. Testing follows automatically. This approach ensures that once set up, there is no chance of the wrong tests being applied to the asset, as is possible with instruments that require a test code to be specified each time that an asset is tested.

The Asset database contains the following details for each asset:

Asset ID – a unique code number (within a particular client), up to 10 characters long. For speed this may be scanned in rather than typed.

Group ID – a code (up to three characters) which identifies which test group should be used when testing the asset. Once again this code may be scanned in, if the tester has a prepared sheet with all the Group ID printed as barcodes.

Serial number – to identify the asset precisely the serial number should be recorded – this may be scanned in too (since many assets now have barcoded serial numbers on them). A maximum length of 15 characters is permitted.

Asset description – a description of the asset, e.g. Manufacturer & Model. This may be scanned too – a prepared sheet with asset descriptions in barcode form must be available. The Asset description may be 20 characters long.

Room ID – in larger organisations, it may be useful to describe the location of an asset more precisely by specifying a Room ID. The **PAT4** remembers the last Room ID specified to save typing it in repeatedly. The Room ID may be up to 10 characters long.

Retest frequency – the retest frequency is set to 12 months by default, but the user may override this to set a different frequency between 1 and 255 months.

VA Rating – the user may optionally specify the Asset's VA rating – often expressed in Watts. It is not permitted to enter anything above 3000.

Fuse rating – the fuse rating may be selected from a scrolling down list – the options are: None, 1A, 2A, 3A, 5A, 10A, 13A.

Adding an Asset

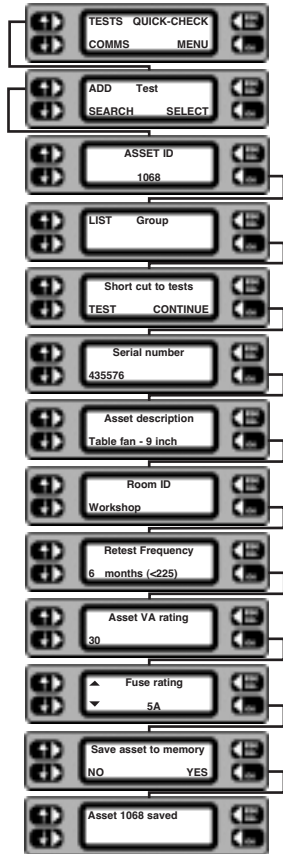

- 1 From the Main screen, press the **TESTS** key.
- 2 Press the **ADD** key.
- 3 Scan in, or type in the asset ID (≤ 10 characters) for the new asset and press the **OK** key.
- 4 Scan in, or type the Group ID (≤ 3 characters) and press the **OK** key.
- 5 Press the **CONTINUE** key.
- 6 Scan in, or type the asset serial number and press the **OK** key.
- 7 Scan in, or type in the asset make/model description and press the **OK** key.
- 8 Accept the displayed room ID, or type in a new room ID name and / or number and press the **OK** key.
- 9 Accept the default re-test frequency of 12 months, or type in the specified number of months between tests and press the **OK** key.
- 10 Type in the VA rating for the asset (often indicated as Watts) and press the **OK** key.
- 11 Toggle the left-hand keys to display the fuse rating for the asset and press the **OK** key (for assets without fuses, NONE may be selected).
- 12 To save the new asset to the memory, press the **YES** key. The option to Test asset now is given. Press the **YES** key to enter directly into the sequence for the selected Group.
- 13 To abort the new asset, press the **NO** key. The details are not saved and the screen returns to the Test screen.
- 14 Press the **ESCAPE** key to return to the Main screen.

Note:-Instead of pressing the **CONTINUE** key (at step 5) you may prefer to press the **TEST** key. This will by-pass the addition of all the remaining asset details and allows you to perform the test straight away. It is recommended that full details are entered, since these enable other features to operate such as the facility to locate an asset by Room ID.

Editing or erasing an Asset

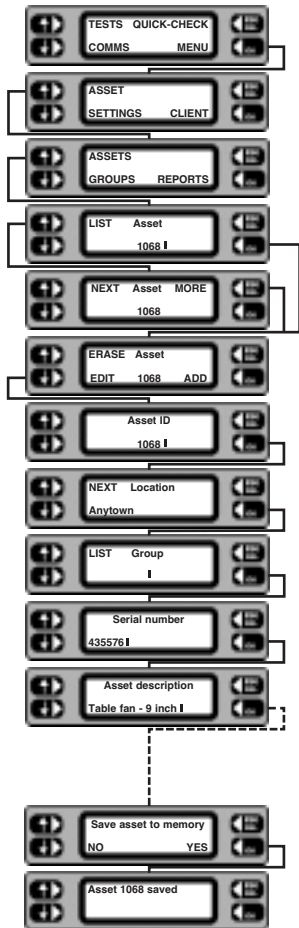

- 1 From the Main screen, press the **MENU** key.
- 2 Press the **ASSET** key.
- 3 Press the **ASSETS** key.
- 4 Scan in, or type in the ID for the required asset and press the **OK** key. Alternatively, press the **LIST** key, then step through the assets using the **NEXT** key.
- 5 If the asset ID is recognised, the Asset screen with options to **ERASE**, **EDIT** or **ADD** is displayed.
- 6 To edit, press the **EDIT** key. Each subsequent screen allows amendments to be made for the selected asset. Press the **OK** key to sequentially step through the details.

To erase, press the **ERASE** key. At the confirmation screen, press the **OK** key to erase the asset, or **ESCAPE** to abort the erase.
- 7 To save the amended asset details to the memory, press the **YES** key. The screen returns to the Asset list screen. Press the **ESCAPE** key to return back to the Menu screen.
- 8 To abort the operation, press the **NO** key. The Asset screen is displayed.

Locate an Asset

It may be necessary to locate and test an asset (for the current Client) for which only the Location, Test Group, or an approximate retest date is known.

Search by location (Location or Room)

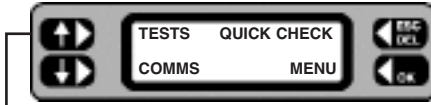

1 From the Main screen, press the **TESTS** key.

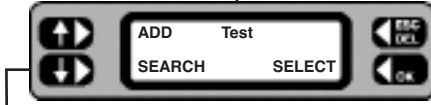

2 From the Test screen, press the **SEARCH** key.

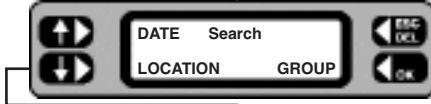

3 Press the **LOCATION** key.

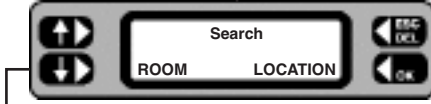

4 Continue the search by selecting **ROOM** or **LOCATION**. The screen changes.
Note: - In order to search by 'Room', the room ID must be specified in the asset details.

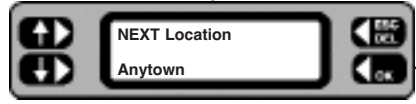

5 If **ROOM** is selected, toggle the **NEXT** key to step through the list of rooms and display the required room. Press the **OK** key.

6 If **LOCATION** is selected, toggle the **NEXT** key to step through the list of locations and display the required location. Press the **OK** key.

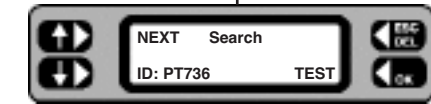

7 Toggle the **NEXT** key to step through the list of assets and display the required asset ID. Press the **TEST** key. The Test screen is displayed.

8. Follow the Test Asset routine.

This facility is very useful if you have to test assets in a large organisation, with many different rooms. You may start in any room or location, and call up all the assets for testing before moving on to the next room or location

Search by Test Group or Test due date

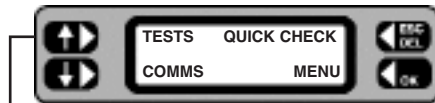

1 From the Main screen, press the **TESTS** key.

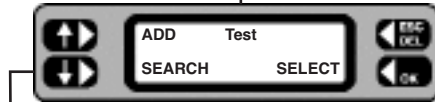

2 Press the **SEARCH** key.

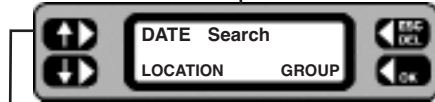

3 Continue the search by selecting either **GROUP** or **DATE**.

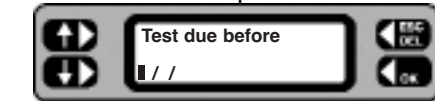
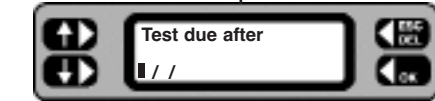

4 For Group search, type in the 3-character code for the Group and press the **OK** key.

Note:-If unsure of the Group code, press the **LIST** key to step through the list of Group codes. Then press the **OK** key.

For search by test due date, type in the date after which the test becomes due and press the **OK** key, then type in the date before which the test is due and press the **OK** key.

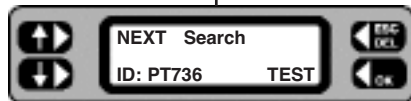

5 Toggle the **NEXT** key to step through the list of assets and display the required asset ID.

6 Press the **TEST** key. The Test screen is displayed.

7 Follow the Test Asset routine.

Testing an Asset

PAT4 will apply each of the allocated tests for the appropriate Group, in the correct sequence. If **AUTOPASS** has been selected under the **SETTINGS** option, testing will proceed automatically with **PAT4** determining the pass/fail status according to the pre selected Group limits. If **MANUAL** has been selected, **PAT4** will pause after each test and display a Pass / Fail decision prompt. An asterisk is placed against either the **PASS** or **FAIL** button depending on whether the value falls within the Test Group's passband.

PAT4 will conduct a pre-test to confirm that electrical continuity exists within the appliance i.e. that it has been switched On, and that any fuses present are not ruptured. If the asset is very high or very low resistance, **PAT4** will warn that the asset may accordingly be Open or Short Circuit. You have the option of **RETRY** (asset turned On?) **FAIL**, or **IGNORE** the warning. Some assets containing heating elements, filament lamps or large motors may offer very low resistance in their de-energised state, causing **PAT4** to warn of a possible short circuit. In such cases, the warning can be ignored. When all required tests have been completed the results may be stored in **PAT4** memory. If a printer is attached to **PAT4**'s parallel output, a simple listing of test results can be printed. If a printer is not attached or this feature has been disabled (See Settings section), **PAT4** will automatically skip the printing process.

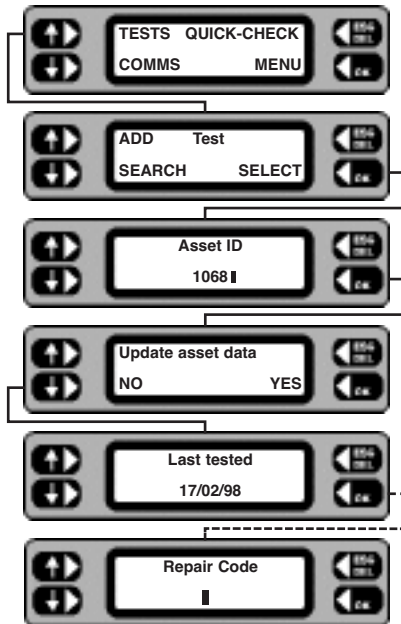

1 From the Main screen, press the **TESTS** key.

2 Press the **SELECT** key.

3 Scan in, or type in the code for the required asset and press the **OK** key.

4 If the asset is recognised, the option to update the asset data is offered. Press the **YES** key to enter the 'Edit Asset' routine or the **NO** key to test the asset now.

5 If previous test results are stored, the date last tested is displayed. Press the **OK** key.

The tests selected in the asset's test group follow on from this point. Refer to the Description of Tests for detailed information on each test.

6 Enter a repair code – if required. **XPress** software™ for Windows has 99 built in codes which you can use when appliance testing to record repair details against tests.

Auto Restart to Main Screen

The Client and Location need be selected only once for any particular site. **PAT4** will assume the same settings until you deliberately logout from the Client. Even if mains power is removed e.g. when moving around a site, if you have not logged out, the **PAT4** will automatically return to the Main screen. You are now ready to test appliances.

Repair Codes

XPress software™ for Windows has 99 built in codes, which you can use when appliance testing to record repair details against tests. With your **PAT4** at the end of the test, you can enter one of these codes and Xpress software will automatically update the repair information in the unassigned or assigned data maintenance programs.

Within **XPress** software™ you can modify the descriptions and add any charge for the repair. The charges will automatically be used on job costing and invoicing. A full list of repair codes currently included is shown opposite. This list may be copied and fixed inside the lid of the test instrument for easy reference if this feature is to be used. If a repair codes are not required simply press the **ESCape** key when the code is requested at the end of the test.

<u>Code</u>	<u>Description</u>	<u>Code</u>	<u>Description</u>
1.	Replace internal fuse.	18.	Renew 3core 0.75mm ² flex
2.	Refit plug.	19.	Renew 3core 1.00mm ² flex
3.	Refit socket.	20.	Renew 3core 1.50mm ² flex
4.	Replace cable	21.	Renew 3core 2.50mm ² flex
5.	Renew 415V 5 pin 16A	22.	Tighten Cord Restraints
6.	Renew 415V 4 pin 32A	23.	Replace Control Knobs.
7.	Renew 415V 5 pin 32A	24.	Tighten Case fixings.
8.	Renew IEC connector 6A	25.	Replace Indicator Lamps.
9.	Renew IEC connector 10A	26.	Replace case parts
10.	Renew IEC connector 16A		
11.	Replace Main Switch.		
12.	Replace Fuse Holder.		
13.	Replace Missing Screws		
14.	Replace Warning Labels		
15.	Renew 2core 1.00mm ² flex		
16.	Renew 2core 1.50mm ² flex		
17.	Renew 2core 2.50mm ² flex		

Historical Data

PAT4 incorporates a historic data facility that enables previous test results to be viewed at the time of testing. This powerful feature enables you to spot any dangerous degradation of the appliance since its last test. Whilst previous and current test results may each be considered acceptable in their own right against the pre-defined limits, there are instances where two very different readings will indicate significant degradation of appliance safety. e.g.

Insulation test March 1998 = 50 MΩ Pass limit = 7 MΩ

Insulation test March 1999 = 10 MΩ Pass limit = 7 MΩ

Both readings are clearly a pass, but if the degradation continued it would not be long before the asset insulation fell below the limit of 7 MΩ causing the appliance to fail the pre-set limits.

Historic test data can only be viewed in Manual test mode (see Setup Autopass/Manual testing). When historic test data is available the test result screen changes slightly. See the insulation test example below.

From previous test

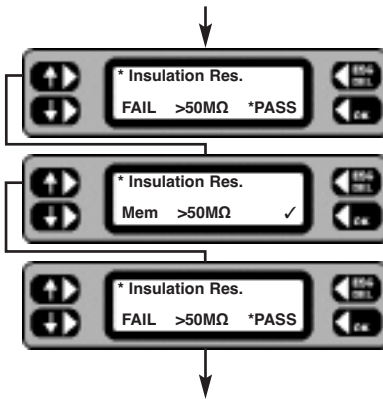

- 1 The Insulation resistance is displayed. The asterisk symbol (*) in the top left corner indicates that historic data is present. To view the historic data, press the asterisk key.
- 2 This example shows that the last insulation test result stored in memory is > 50MΩ and the ✓ indicates that this was a pass at the last test. If the asset had failed the test an ✗ would be displayed.
- 3 To revert to the current test result simply press the asterisk * key again and **PASS** or **FAIL** the test. The test sequence for the appliance continues.

To next test

PAT4 stores both the current and the previous test results for each asset.

When data is uploaded to **PAT4** from **XPress** software™, the historic data will also be transferred. However, data will not be transferred if the previous test was not performed using a **PAT4**.

Quick-Check

It is often useful to perform a particular test on an asset in isolation. If for instance an asset had previously failed a particular test and had subsequently been repaired it may be useful to verify the repair before commencing with a full test sequence. Alternatively the test could be used during repair in order to highlight the area at fault. Quick-check enables the selective application of any of the tests that would normally be applied to the asset. The asset ID is entered in the normal way, recalling the asset record. The individual tests specified for the asset group will then be displayed, allowing any one to be run independently. In Quick-check mode no results are stored and the asset history is not changed.

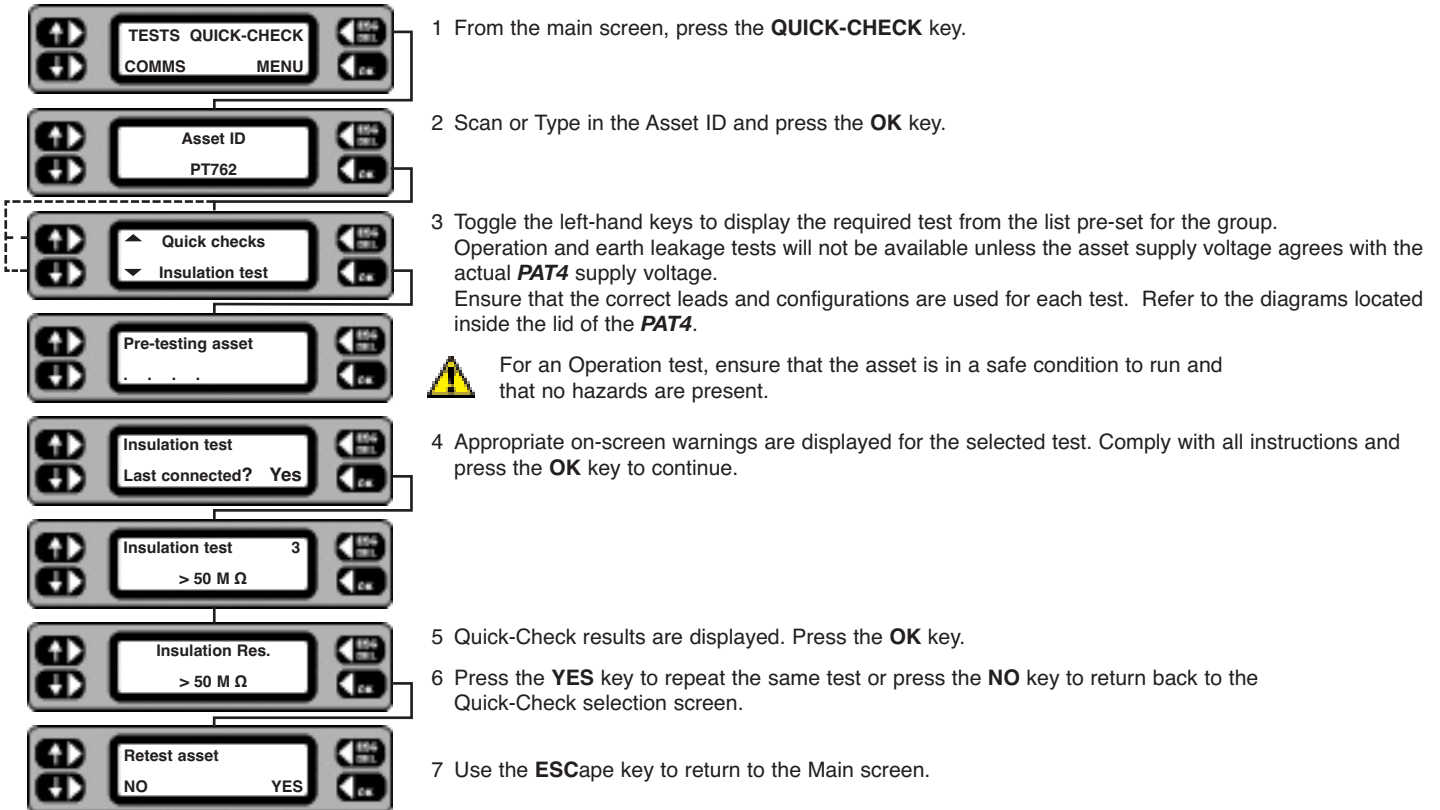

Erase Memory

From time to time you may wish to permanently erase all or part of the memory on your **PAT4**. Options are as follows:-

- Erase Groups
- Erase Locations
- Erase Results
- Erase ALL
- Erase Clients
- Erase Assets
- Erase Setup

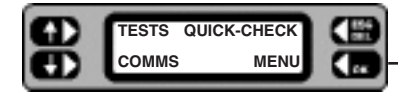

1 From the Main screen, press the **MENU** key.



2 From the Menu screen, press the **SETTINGS** key.

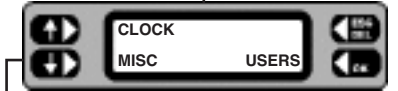

3 Press the **MISC** key.



4 Press the **MEMORY** key.

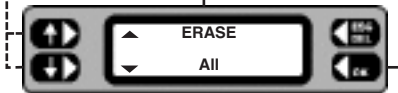

5 Toggle the left-hand keys to display the item to be erased.

6 Press the **OK** key. The selected items are erased.

Note 1: - Once erased, the data cannot be un-erased.

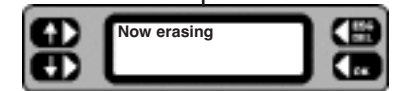

7 On completion press the **ESCape** key to return back to the Menu screen.

Note 2: - Erasure of Clients or Locations will include all related assets, and is pre-empted by a check. Confirm (**OK** key) or cancel (**ESC** key) to continue.

Note 3: - On completion of the erasure routine, **PAT4** returns to the Login screen for 'Erase All' and to the Client screen for 'Erase Locations' and 'Erase Client'.

Note 4: - Prior to erasing assets or results, **PAT4** performs a check on the number of assets or results to be erased. Confirm **OK** or cancel (**ESCape** key).

Printing Reports and Results

A variety of reports are available for printing directly from the **PAT4**, providing the advantages of hard copy output on site. **PAT4** permits the printing of the following range of reports:

- Client List
- Plain Asset List †
- Retro report
- Assets with Due dates for testing †
- Location List
- Assets with Current Results (Certificate of Test) †
- Groups

All reports are printed directly from the **PAT4** using the parallel printer connector on the front panel.

† The asset and results reports indicated list the assets and results that relate to the current Client and Location.

The 'Retro' report produces a report which is compatible with the data which may be downloaded into "Shire's" 'Safety First', 'Safety First+' packages. However it must be remembered that the output for this report selection will appear on the parallel output of the PAT4. The above software packages can only receive data via a PC serial port. It will therefore be necessary to pass the data through a parallel to serial converter, if you wish to download from the **PAT4** to any of these packages. These are readily available at low cost from many sources.

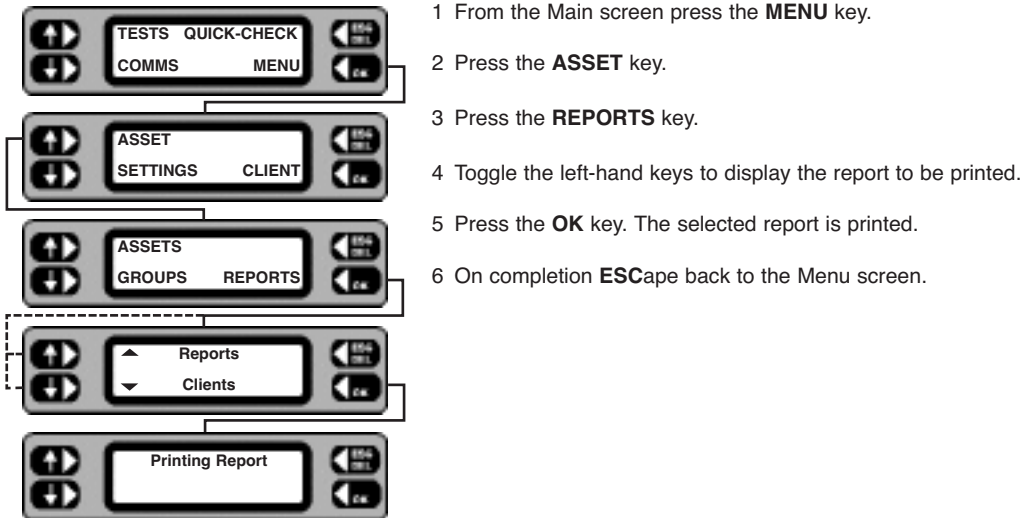

If a printer is attached to **PAT4**'s parallel output during the testing of assets, a simple listing of test results can be printed at the end of each test. (This feature must be enabled first - see Settings section).

Download/Upload Data

PAT4 is designed to be used in conjunction with **Download Manager™** or **XPress™** software for Windows™ which can send and receive fields within its database to form a highly integrated portable appliance testing system. **PAT4** may be controlled from **Download Manager™** or **XPress™** software, providing a centrally administered testing regime. In this way the manipulation of large quantities of data is handled on a PC, each **PAT4** acting as a slave to receive information on Clients, Locations and assets to be tested. The data and test results can then be downloaded to the PC as convenient. To download or upload data, the **PAT4** needs to be connected to a PC running suitable download software i.e. **Download Manager™** or **XPress™** software for Windows™.

XPress™ software for Windows™

This Windows package produces certificates for Portable Appliance Testing. The database stores a wide variety of appliance and customer information, together with a full test history. Test data may be edited, repairs added and power searches and sorts performed.

Serial Lead Connections

A 9 way lead is supplied with the **PAT4**. The following table indicates the lead format required. Some PCs require a 25 way connector.

Signal	PAT4	PC	PC
		9 way 'D'	25 way 'D'
DCD	1	7	4
RXD	2	3	2
TXD	3	2	3
DTR	4	6/8	5/6
GND	5	5	7
DSR	6	4	20
RTS	7	1	8
CTS	8	4	20
+5V	9	9	22

Download to a computer

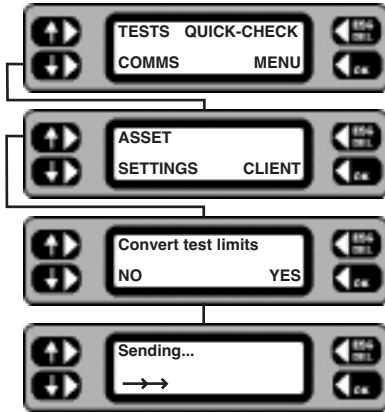

- 1 Connect the **PAT4** to the PC, and prepare the PC software to receive the data.
- 2 From the Main screen, press the **COMMS** key.
- 3 Press the **SEND** key.
The display may briefly display 'Connecting' as it establishes a connection with the PC.
- 4 If the PAT4 detects that the PC software is not set up to work with the latest IEE Code of Practice pass limits, PAT4 will prompt whether you want to convert the downloaded group data to use the nearest pass limit available.
- 5 The display shows that the data is downloading.

Upload from a computer

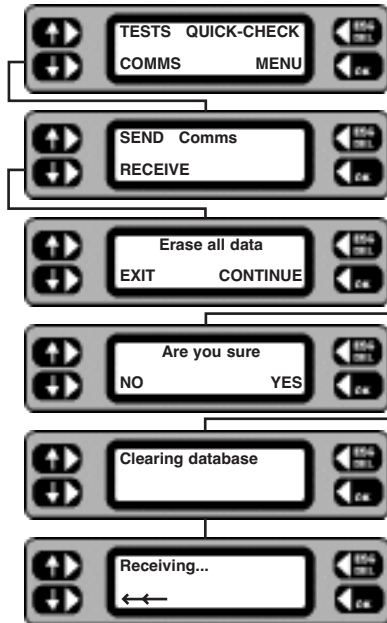

1 Connect the **PAT4** to the PC, and prepare the PC software to send the data.

2 From the Main screen, press the **COMMS** key.

3 Press the **RECEIVE** key.

4 Press the **CONTINUE** key.

Note:- This will erase all current data. Only proceed if this data has been downloaded first, or is of no further use.

5 Press the **YES** key – all the data in the **PAT4** will be erased, then it will start receiving data from the PC.

6 The database is cleared prior to receiving the data from the PC.

The display should briefly display 'Connecting' as it establishes a connection with the PC.

7 The display shows that the data is being received.

Description of Tests

Visual Inspection List.

The Visual Inspection is to check the condition of:

- Case for damage; tears; cracks.
- Mains Plug.
- Mains Lead.
- On/Off Switch.
- Supply socket.
- Environment e.g. operational hazards nearby.
- Suitability i.e. used for correct purpose.
- Everything Else.

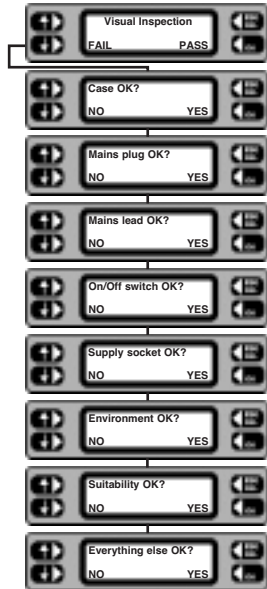

- 1 The test screen prompts the user to select either **PASS** or **FAIL**, if **PASS** is selected the test will progress onto the next selected test in the group.
- 2 If **FAIL** is selected, then the screens will prompt to specify the nature of all the faults noted.
- 3 Press **YES** or **NO** to specify the Visual inspection failures.
- 4 Check for any hazards in the vicinity, e.g. asset is exposed to water.
- 5 Check asset is suitable for the task it is being used for.
6. Any other hazards present.

Note: - If an asset fails the visual inspection, no further tests will be performed and a repair code may be entered (see 'Repair Codes').

Description of Tests

Earth Bond Test

In order to adequately test the integrity of the appliance earth conductor, high current (10A or 25A a.c.) is passed between the Earth Bond terminal and the appliance test socket earth pin. The current may be set to 10A or 25A (calibrated at 0.1). The **PAT4** can store upto three separate earth bond test results for each asset test.

The **PAT4** contains thermal overload protection, which may operate in extreme cases of repeated earth bond testing. The message “Bond test is too hot” will be displayed and the test will be aborted. Testing may recommence after a 10 minute cooling period. If this occurs frequently, refer to Settings and reduce the Earth Bond test time. We recommend a duration of 5 seconds for this test.

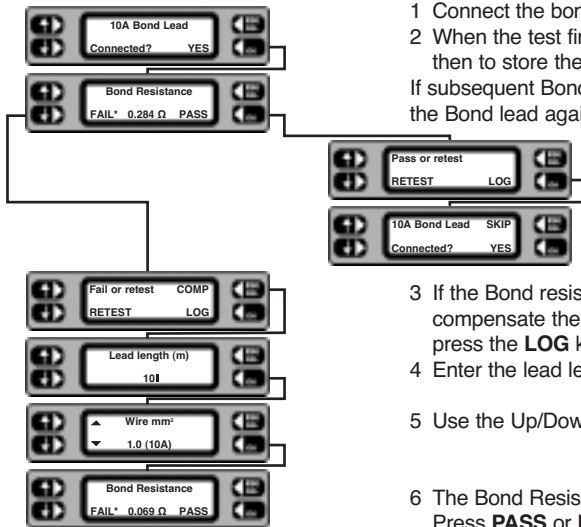

1 Connect the bond lead to a suitable point on the asset under test. Press the **OK** key.

2 When the test finishes the final result is shown. If the result is **OK**, press **PASS**, then to store the result press **LOG**.

If subsequent Bond tests are not required press the **SKIP** key when prompted to connect the Bond lead again.

3 If the Bond resistance is too high, press the **FAIL** key. If the asset has a long supply lead you can compensate the Bond reading to allow for this by pressing the **COMP** key. To fail the asset immediately, press the **LOG** key.

4 Enter the lead length in metres.

5 Use the Up/Down keys to select the cross sectional area of the earth conductor.

6 The Bond Resistance is re-displayed taking into account the supply lead resistance. Press **PASS** or **FAIL** as appropriate.

Earth Continuity Test

This test provides a measurement of protective conductor resistance and is therefore applicable to Class 1 assets only. This test is usually applied to equipment which may be damaged by the high current Bond test (e.g. I.T. equipment).

A low current (D.C.) is passed between the Continuity terminal and the appliance test socket Earth pin. The test current is limited to 200 mA with a maximum open circuit voltage of 4 V. To use this test the Continuity terminal and the black lead should be connected to the appliance's exposed metalwork. On completion of the Continuity test, ensure that the black earth lead is disconnected from the appliance under test.

The procedure for this test is very similar to the Bond test (some screen titles are changed).

Description of Tests

Circuit Test. (Pre-Test)

Prior to performing any of the main tests an initial check is performed to indicate an approximate value of appliance loop impedance. Abnormal results from this test displays a message indicating the conditions that may affect the validity of the tests to be performed, or where possible damage to the **PAT4** may result. When everything is in order, no message is given. The flowchart below shows the other possible displays.



• Open circuit - Check asset On/Off switch and /or fuse.

• Short circuit - Check asset before continuing.

Note that some assets containing heating elements, filament lamps or very large motors may exhibit a very low resistance in their de-energised state, causing **PAT4** to warn of a possible short circuit. In such cases, the warning can be ignored. **Note:-** If an operation test is carried out on a short circuit asset, **PAT4** may be damaged. If in doubt **DO NOT PROCEED**. Press the **FAIL** key, suitably label, and remove the asset from service; investigate and rectify the fault, and re-test on completion. The asset is energised from a low potential / low energy a.c. supply. The open circuit voltage is typically 12 Volts (peak) with a short circuit current of 100 mA.

Insulation Test

A 500 Volt D.C. source is used to provide the Insulation test function. Class 1 appliances, are tested by applying 500V between Earth and the two-phase conductors joined together. Class 2 appliances should be tested using the Bond test lead as a return connection. The insulation test voltage is applied to the appliance phase conductors as for Class 1, but any current flow will return to Earth via the bond test lead which should be connected to the appliance insulation or to any exposed metal parts. The insulation test has been designed to supply 500 V at 1 mA.

Operation Test



For an Operation test ensure that the asset is in a safe condition to run and that no hazards are present.

Operation tests allow the power consumed by the equipment to be checked against the manufacturers rating. The measurement is displayed in Volt Amps (VA) often specified on assets as Watts.

During the Operation test the appliance is powered directly from the incoming mains supply (230V or 110V). During the test the **PAT4** also measures the mains voltage at the time of test. If this is found to vary from the nominal mains value (230 V or 110V) **PAT4** will make a correction and display the consumed power as if the mains voltage had been exactly correct. This enables a more accurate comparison with the manufacturers figure.

Description of Tests

Earth Leakage (Touch Current) Test

Note: the Earth Leakage (Touch Current) test is carried out concurrently with the Operation test.

The earth leakage test determines whether any current is flowing to earth. Normally appliances should have no or very little earth leakage current. The **PAT4** can also detect earth leakage in Class 2 (Double insulated) assets. This enables account to be taken of all leakage paths to earth rather than just that flowing in the earth wire if applicable. e.g. a Class 2 (Double insulated appliance) could exhibit earth leakage through its mountings or by operator contact.

To carry out a Touch Current test on a Class 2 asset, the operator should connect the bond test lead to any accessible surfaces of the asset. To carry out a Touch Current test on a Class 1 asset, connect the bond test lead to any unbonded metalwork on the asset.

During the test the actual mains voltage is also measured at the appliance socket. In order to ensure that the equipment is safe even when the mains supply rises to its maximum permitted value (253V or 121V in the UK) the **PAT4** calculates and displays the leakage (Touch) current that would flow at this value.

Fuse Test

During appliance testing it is often necessary to check the integrity of a fuse. **PAT4** incorporates an integral fuse tester on the front panel. To test a fuse hold the fuse to be tested onto the two pads, the **PAT4** will bleep if the fuse is intact.

Extension Lead Testing

Most types of extension leads (including IEC leads, 13 Amp extension leads and 110V BS4343 extension leads) can be tested. Leads are tested for open and short circuits, correct polarity, Insulation resistance, and Earth conductor resistance. A simple visual inspection option is also included. Leads are tested by connecting between the appropriate 230 V or 110V socket and the IEC Lead test socket on the front panel. Where the lead to be tested is not compatible with the IEC lead test socket a short adapter lead should be used to make the connection. See 'Accessories'.

Description of Tests

Flash Test (PAT4 DVF only)

 A flash test (dielectric strength test) is usually a manufacturers type test and should not normally be carried out as a routine test. The test stresses the asset insulation, and can in some cases actually cause damage. However it may be advisable to perform a flash test if the asset concerned has been completely overhauled.

In cases where assets contain interference suppressors, the flash test may need to be omitted if the voltage withstand rating of the suppressor(s) is insufficient. Alternatively these components may be disconnected.

Never perform a flash test if there is any doubt!

Safety precautions

 A flash test on a Class 1 asset applies 1500 V a.c. to the asset supply lead (L/N conductors) and this voltage will exist within the asset being tested. For a Class 2 asset, 3000 V a.c. is applied from the tip of the flash probe. In the case of a faulty asset, physical contact with any part of the asset may give an electric shock. Do not touch, or allow anyone else to touch the asset under test.

It is the responsibility of the user to take the necessary precaution to prevent danger to themselves and to other persons.

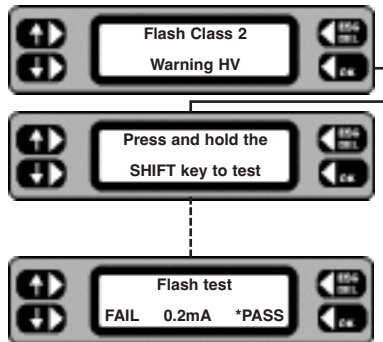

- 1 For Class 2 assets, connect the flash test probe. Press the **OK** key to proceed. Check that it is safe to proceed.
- 2 To prevent accidental application of the flash test, the **SHIFT** key must be held down for the duration of the test. If the key is prematurely released, the test will be aborted.
- 3 For Class 2 assets, hold the test probe against the appliance insulation or to any exposed metal parts.
- 4 When the test finishes, press **PASS** or **FAIL** as appropriate.

Demonstration Test Groups

To enable you to get started, ten test Groups have been included to cover a variety of equipment types. They may be used, deleted or modified at any time.

CODE	USAGE	TESTS APPLIED	PASS LIMITS SET
SC1	Standard Class 1 Earthed Equipment	Visual Inspection Earth Bond at 10A Insulation Operation (230V) Earth Leakage (230V)	0.1Ω or less 2.0MΩ or more 3kVA or less 3.5mA or less
SC2	Typical Class 2 Double Insulated	Visual Inspection Insulation Operation (230V) Earth Leakage	7.0MΩ or more 3kVA or less 0.5mA or less
TO1	110 V Tools Earthed at 25A	Visual Inspection Earth Bond Insulation Operation (110V) Earth Leakage (110V)	0.1Ω or less 2 MΩ or more 2 kVA or less 3.5 mA or less
TO2	110 V Tools Double Insulated	Visual Inspection Insulation Operation (110V) Earth Leakage (110V)	7 MΩ or more 2 kVA or less 0.5 mA or less
EL1	230V Extension Leads 3 Core	Visual Inspection Earth Bond at 25A Insulation Polarity	0.5Ω or less 7 MΩ or more Correct polarity of conductors
EL2	230V Extension Leads 2 Core	Visual Inspection Insulation Polarity	5 MΩ or more Correct polarity of conductors
FAN	Desk Fan Double Insulated	Visual Inspection Insulation Operation Test (230V) Earth Leakage (230V)	7 MΩ or more 200 VA or less 0.5 mA or less
PC	Personal Computer IT Equipment	Visual Inspection Earth Continuity Operation (230V) Earth Leakage (230V)	0.1Ω or less 500 VA or less 3.5mA or less
DRY	Hairdryers Double Insulated	Visual Inspection Insulation Operation (230V) Earth Leakage (230V)	7 MΩ or more 1.5 kVA or less 0.5 mA or less
KET	Kettles Earthed	Visual Inspection Earth Bond at 25A Insulation Operation (230V) Earth Leakage (230V)	0.1 Ω or less 2.0 MΩ or more 2.5 kVA or less 3.5mA or less
EL3	110V Extension Leads 3 Core	Visual Inspection Earth Bond at 25A Insulation Polarity	0.5Ω or less 7 MΩ or more Correct polarity of conductors

Demonstration Assets

Note:- Groups **P4A** to **P4E** are also included in your demonstration data. These are used to calibrate your **PAT4** at the factory, and may be deleted. The following assets have been added for the AVO International Client at the Manufacturing Site.

Appliance ID	Test Group	Serial number	Description	Room	Re-test frequency	VA	Fuse Rating
F131	FAN	CANA12	Canarm 3 speed	Office	24 Months	60	3A
F132	FAN	CANA134	Canarm 3 speed	Office	24 Months	60	3A
T1234	SC1	None	Soldering Iron	Workshop	6 Months	75	3A
1292-282	SC1	XER-667	Xerox Copier	Sales	12 Months	900	5A
T2985	PC	DP-7274594	DELL Pentium	Lab 1	24 Months	500	3A
CFR2453	SC2	KP329	Krupps Coffee	Office	12 Months	2000	10A
354713	SC2	None	Avery Scales	Stores	12 Months	140	3A
LP2345	SC2	None	Desk Lamp	Lab 1	12 Months	60	3A
T45	TO1	TTD23-DRF	Hilti Drill	Maintenance	6 Months	1030	None

The following assets have been added for the AVO International Client at the Technical Services Site.

Appliance ID	Test Group	Serial number	Description	Room	Re-test frequency	VA	Fuse Rating
PC1	PC	1237919	DELL P560-L	Support	24 Months	460	3A
PC2	PC	029337	SPIRE Pentium 133	Support	24 Months	650	3A
PC3	PC	13093029	DAN Pentium 200	Shop	24 Months	975	5A
PC4	PC	0939287	DELL Notebook	Sales	12 Months	300	3A
PC5	PC	1237183	Network Server	Design	24 Months	890	5A
COP1	SC1	SH100-29	SHARP 2000	Shop	12 Months	800	5A
KET1	KET	823-368	SWAN Slimline	Old Office	12 Months	2000	10A
FAN1	FAN	None	COOLBOY 30	Design	12 Months	75	3A
FAN2	FAN	None	VANE 130	Design	12 Months	100	3A

The following assets have been added for A.N.Other Client at the Dover Location. NB:- No other appliances exist for the other sites.

Appliance ID	Test Group	Serial number	Description	Room	Re-test frequency	VA	Fuse Rating
PT736	TO1	H637-27	Angle Grinder	Loan Store	3 Months	1200	None
PT874	TO1	H/23EW	Flood Lights	Loan Store	3 Months	1500	None
PT9085	TO1	YT/45	Flood Lights	Loan Store	3 Months	1500	None
PT14	TO2	FFR736	0.5" Drill	Loan Store	6 Months	900	None
PT46	TO2	2763737	Sander	Loan Store	6 Months	800	None
ST3880	FAN	None	Desk Fan	Reception	12 Months	90	3A
T423	SC1	None	Compressor	Loan Store	6 Months	2500	13A
T35	SC2	None	Table Light	Reception	12 Months	60	3A
DR36	SC2	None	Table Light	Reception	12 Months	60	3A

Note:- A number of assets have also been added for Yet Another Client, Building 1. These are used at the factory for calibrating PAT4, and may be deleted by erasing the Client data.

Specification

Circuit test

Test Voltage: 12 V p - p, 50Hz square wave. (Typical)
Max current: 100 mA (typical)
Indications: Open circuit, OK, Short circuit.

Insulation test

Range: 0 - 50 M Ω
Accuracy: 5.0% \pm 100 k Ω
Compliance: 500 V at 0.5 M Ω
Pass Band options: 0.25M Ω , 0.3M Ω , 0.5M Ω , 1M Ω , 2M Ω , 4M Ω , 5M Ω , 7M Ω , 8M Ω , 10M Ω , 20M Ω , 50M Ω

Earth Bond Test

Range: 0 - 999 m Ω Resolution 1 m Ω
1000 - 1999m Ω Resolution 10 m Ω
Accuracy: 0 <R> 499 m Ω 5.0% \pm 5m Ω
500 m <R> 1999 m Ω 5.0% \pm 50m Ω
Test Voltage: 10 V a.c. (Typical)
Test Current: 10A or 25A into 0.1 (typical)
Pass Bands: 50 m Ω , 100 m Ω , 200 m Ω , 300 m Ω , 400m Ω , 500m Ω , 600m Ω , 750m Ω , 800m Ω , 1 Ω , 1.5, 2

Earth Continuity Test

Range: 0 - 999 m Ω Resolution 1 m Ω
1.00 - 9.99 Ω Resolution 10 m Ω
Accuracy: 5.0% \pm 10m Ω
Test Voltage: 4 V d.c. (Typical)
Test Current: 200 mA short circuit (typical)
Pass Bands: 50 m Ω , 100 m Ω , 200 m Ω , 500 m Ω , 750m Ω , 1 Ω , 1.5 Ω , 2 Ω , 2.5 Ω , 5 Ω , 7.5 Ω , 10 Ω

Operation Test

Range: 0 - 3.0 kVA.
Accuracy: 0 <VA> 99 VA: 5.0% \pm 5 VA
100 <VA> 999 VA: 5.0% \pm 10 VA
1.0 <VA> 3.0kVA: 5.0% \pm 100 VA
Reference: Reading corrected to 230 V
Pass Band options: 50 VA, 100 VA, 200 VA, 350 VA, 500 VA, 700 VA, 1000 VA, 1200 VA, 1500VA, 2000 VA, 2500 VA, 3000 VA.

Specification

Earth Leakage Test

Range:	0 - 15 mA
Accuracy:	$\pm 5.0\% \pm 100 \mu\text{A}$ (@ 50Hz) ($\pm 20\%$ @ 60Hz)
Reference:	Reading corrected to 253 V
Pass Band options:	0.25mA, 0.5mA, 0.75mA, 1mA, 1.5mA, 2mA, 3.5mA, 5mA, 7mA, 7.5mA, 10mA, 15mA

Flash Test (PAT4 DVF)

Range:	0 – 3.5mA
Accuracy:	$\pm 5\% \pm 200 \mu\text{A}$
Test voltage:	Class 1 – 1500 V a.c. (typical) Class 2 – 3000 V a.c. (typical)
Pass Band Options:	0.2mA, 0.3mA, 0.4mA, 0.5mA, 0.6mA, 0.75mA, 1mA, 1.2mA, 1.5mA, 2mA, 2.5mA, 3mA

Fuse Test

Test Voltage:	5 V d.c. typical
Test Current:	500 μA short circuit typical
Indication:	Audible using internal bleeper

Extension Lead test

Test Voltage:	5V d.c. typical
Test current:	1 mA short circuit typical
Indication:	Lead short circuit (Live to Neutral) Lead open circuit (Live or Neutral) Live / Neutral transposed Lead OK Bond and Insulation test follow OK condition.

Mains supply

Input Voltage Range: The PAT4 DV contains an automatic mains voltage changeover system. To test 110V appliances an external 110 Volts source must be provided.

Operating Voltage:	230 Volt: 207 - 253 Volts 50Hz / 60Hz* 110 Volt: 99 – 121 Volts 50Hz.
Fusing:	FS 13 Amp to BS1362.

Safety Specifications

Meets the requirements of IEC 1010-1 (1995) EN 61010-1 (1995) phase to earth Installation Category II** for Safety Class 1

EMC: In accordance with IEC61326 including amendment No.1

* See Earth Leakage tolerance for 60Hz operation.

Specification

Environmental Specifications

Designed for indoor use or protected outdoor use.

Operational Temp Range: 0° - 40° C at 90% Relative Humidity

Storage Temp Range: -20° C to 60°C

Temperature co-efficient: 0.2% per °C (Ref temp. 20°C)

General features

Hard copy of results formatted as a pass / fail list.

On board real time clock module.

On board AVO Xpress software compatible asset database.

On board storage for 1000 test results (max).

Alphanumeric key pad.

Auto / Manual modes.

Two line LCD text display.

Communication Connectors

9 way male 'D' RS232: Interface to PC / bar code scanner

8 bits, no parity, 1 stop bit.

PC: 9600 baud

Scanner: 2400 baud.

25 way female 'D': Parallel printer for results.

Cleaning

Disconnect instrument from mains supply. Wipe with a clean cloth dampened with soapy water or Isopropyl Alcohol (IPA).

Mechanical Specifications.

Weight: 6 kg (DV)

6.95 kg (DVF)

Dimensions: Width - 375 mm (inc handle and lid)

Depth - 330 mm (inc hinges)

Height - 200 mm (approx).

Accessories

Included Accessories

Item	Cat.No.
Appliance Tester PAT4	
User Guide	6172-706
Mains Lead 230V - 16A	6121-282
Bond Test Lead and clip (Black)	6231-043
Flash Test Probe (PAT4 DVF only)	5310-401
Serial PC Download Lead	25955-025
RS232 Powered Download Lead (for PC' s with low voltage serial ports)	6220-739

Optional Accessories

Item	Cat.No.
Bar Code Scanner 72mm	6231-623
Barcode PAT Testing Labels	6121-483
PAT Testing Labels	6171-418
Earth Bond Probe Assembly	6320-225
"Safe Block" Adaptor Lead	6331-230
110V – 16A Supply Lead	6220-631
Adaptor for 110V plug to 110V socket extension lead	6231-547
Adaptor for 13A plug to 13A extension lead	6220-632
Results Printer	6220-665
Self Adhesive Label roll for 6220-665	25995-016
Plain Paper rolls (for 6220-665)	10005-265
Parallel Printer Lead	25970-024
Xpress software	6111-443
Powersuite software	Various
Download Manager Software	6111-442

Training media

Item	Cat. No.
VHS Video 'Portable Appliance Testing 2'	6131-999

Repair and Warranty

The instrument contains static sensitive devices, and care must be taken in handling the printed circuit board. If an instrument's protection has been impaired it should not be used, but sent for repair by suitably trained and qualified personnel. The protection is likely to be impaired if for example, it shows visible damage, fails to perform the intended measurements, has been subjected to prolonged storage under unfavourable conditions, or has been subjected to severe transport stresses.

NEW INSTRUMENTS ARE GUARANTEED FOR 1 YEAR FROM THE DATE OF PURCHASE BY THE USER.

Note: Any unauthorized prior repair or adjustment will automatically invalidate the Warranty.

CALIBRATION, REPAIR AND SPARE PARTS

For service requirements for Megger Instruments **contact:**

Megger Limited	or	Megger
Archcliffe Road		Valley Forge Corporate Centre
Dover		2621 Van Buren Avenue
Kent CT17 9EN		Norristown PA 19403
England.		U.S.A.

Tel: +44 (0) 1304 502 243 Tel: +1 610 676 8579

Fax: +44 (0) 1304 207 342 Fax: +1 610 676 8625

Megger operate fully traceable calibration and repair facilities, ensuring your instrument continues to provide the high standard of performance and workmanship you expect. These facilities are complemented by a worldwide network of approved repair and calibration companies to offer excellent in-service care for your Megger products.

Returning your product to Megger - UK and USA service centres

1. When an instrument requires recalibration, or in the event of a repair being necessary, a Returns Authorisation (RA) number must first be obtained from one of the addresses shown above. You will be asked to provide the following information to enable the Service Department to prepare in advance for receipt of your instrument, and to provide the best possible service to you.
 - Model, e.g. PAT4 DVF3.
 - Serial number, to be found on the underside of the case or on the calibration certificate.
 - Reason for return, e.g. calibration required, or repair.
 - Details of the fault if the instrument is to be repaired.
2. Make a note of the RA number. A returns label can be emailed or faxed to you if you wish.
3. Pack the instrument carefully to prevent damage in transit.
4. Ensure the returns label is attached, or that the RA number is clearly marked on the outside of the package and on any correspondence, before sending the instrument, freight paid, to Megger. Copies of the original purchase invoice and packing note should be sent simultaneously by airmail to expedite clearance through customs. In the case of instruments requiring repair outside the warranty period, an immediate quotation can be provided when obtaining the RA number.
5. You may track the progress of your return on line at www.megger.com

Approved Service Centres

A list of Approved Service Centres may be obtained from the UK address above, or from Megger's website at www.megger.com

Megger®

Megger Limited
Archcliffe Road, Dover
Kent CT17 9EN England
T +44 (0)1 304 502101
F +44 (0)1 304 207342
E uksales@megger.com

Megger
4271 Bronze Way, Dallas,
Texas 75237-1019 USA
T +1 800 723 2861 (USA ONLY)
T +1 214 333 3201
F +1 214 331 7399
E ussales@megger.com

Megger
Z.A. Du Buisson de la Couldre
23 rue Eugène Henaff
78190 TRAPPES France
T +33 (0)1 30.16.08.90
F +33 (0)1 34.61.23.77
E infos@megger.com

Megger Pty Limited
Unit 26 9 Hudson Avenue
Castle Hill
Sydney NSW 2125 Australia
T +61 (0)2 9659 2005
F +61 (0)2 9659 2201
E ausales@megger.com

Megger Limited
110 Milner Avenue Unit 1
Scarborough Ontario M1S 3R2
Canada
T +1 416 298 9688 (Canada only)
T +1 416 298 6770
F +1 416 298 0848
E casales@megger.com

Megger products are distributed in 146 countries worldwide.

**This instrument is manufactured in the United Kingdom.
The company reserves the right to change the specification or design without prior notice.**

Megger is a registered trademark

Part Number 6172-706 – V11 – Printed in England 0606

www.megger.com